

BICYCLE GUARD | LINK



BICYCLE GUARD LINK
Ref: 11 0560 / 11 0560 ENL

➤ Type of wood



➤ Colours

Colours shown :

Wood: Ash with clear autoclave treatment
Frame: Galvanised steel, not painted

*Legs also available in zinc and powder coated steel.
Colours can be selected from the RAL shades or other textured shades from the Akzo Nobel Futura range.*

➤ Presentation

This bicycle stand is part of the contemporary Link range. The contemporary reinterpretation of this furniture brings sobriety, elegance and conviviality for an effective integration in any type of environment. The Link range is eco-conceived, the design limits the consumption of raw material by simple shapes and optimizes transport.

➤ Description

The bicycle stand is made of a 4 mm thick **galvanised steel support** and a 50 x 45 mm **wooden slat** available in **ash** (autoclave treatment not painted) or **exotic wood** (without stain).

Our woods are exclusively collected in sustainably managed forests. Of high quality, they are **PEFC labeled** for local sourcing, FSC® labeled for exotic hardwoods, or comply with the EUTR (EU Wood Regulations). The ash undergoes a colourless fungicidal and insecticidal treatment by autoclave.

For optimum protection against rust and long-term performance, the steel elements are zinc coated first, and go through our powder blast process (after having being cleaned and shot-blasted, the parts are coated with a primary layer of epoxy powder, followed by a second layer of polyester powder) **or hot-dip galvanized** (immersion of the parts in a bath of molten zinc at 450°).

The slat is fixed to the support with inserts in the wood and screws.

The sealing base plates are 6 mm thick.

4 sealing points Ø 13 mm for the base plate version.

Delivered assembled.

➤ Dimensions

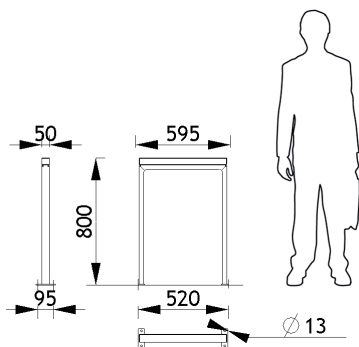

Link Bicycle guard
Ref: 11 0560 - 7 kg

➤ Sealings

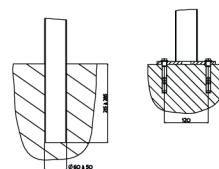

To be buried
TYPE A

Base plate
TYPE B

