

# BICYCLE GUARD | LARGE ARCH



**LARGE ARCH**  
Ref: 43 0150 / 43 0151



**LARGE ARCH WITH PARKING PATTERN PLATE**  
Ref: 43 0154 / 43 0155

## Colours

**Colours shown:**  
Bicycle guard: Sand grey 900  
Plate: Sand grey 900

*Colours can be selected from the RAL shades or other textured shades from the Akzo Nobel Futura range.*

## Presentation

The bicycle guard encourages the development of cycling in the city.

The bicycle guard has been designed and developed in a specific Sineu Graff eco-design approach. They have a sober design. This design has been optimised to reduce raw materials and energy to manufacture.

## Description

The bicycle guard is made of a zinc and powder coated steel bent tube Ø42 mm and 8 mm thick.

The plate is made of 5 mm thick steel with a laser-cut "Bicycle parking" pictogram.

**For optimum protection against rust and long-term performance**, the steel elements are zinc coated first, and go through our powder blast process (after having being cleaned and shot-blasted, the parts are coated with a primary layer of epoxy powder, followed by a second layer of polyester powder).

The sealing base plates are 8 mm thick.

4 sealing points, Ø 13 mm, for the base plate version.

Delivered assembled.

## Dimensions

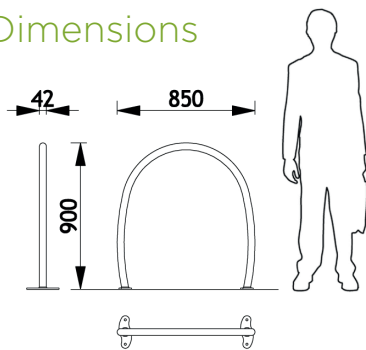

**Large Arch**  
Ref: 43 015x - 8 kg

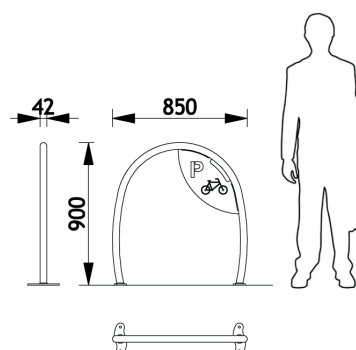

**Large Arch with parking pattern plate**  
Ref: 43 015x - 11 kg

## Sealings

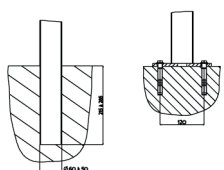

To be buried  
TYPE A

Base plate  
TYPE B

