

LITTER BINS | STAINLESS STEEL RANGE - DIAMOND POINT ROUND



ROUND

Bag holder: 46 L - Ref. **20 0510 INX**

Bag holder: 60 L - Ref. **20 0512 INX**

Bag holder: 80 L - Ref. **20 0514 INX**

Liner: 40 L - Ref. **20 0511 INX**

Liner: 55 L - Ref. **20 0513 INX**

Liner: 75 L - Ref. **20 0515 INX**

Colours

Colours shown:

Body, lid and base : stainless steel

Presentation

This round litter bin is entirely made of stainless steel, with a diamond-point pattern body for maximum strength.

Description

The litter bin is entirely made of 316L stainless steel, is composed of a 2,5 mm thick body, embossed with the "Diamond Point" pattern, a 2,5mm thick lid and a 4 mm thick base.

Bag holder version: the bag holder is made of steel and is hinged.

Liner version: the liner is made of 304 L stainless steel for increased durability and high resistance

The stainless steel is treated, after manufacturing, by sanding, electro-polishing for the lid and bead-blasting for the body, then passivation.

The lid of the litter bin is connected to the body with hinges.

The body of the litter bin is fixed to the base with screws.

Closing is automatic and opening is to be done with a triangular key.

3 sealing points Ø 13 mm.

Delivered assembled.

Dimensions

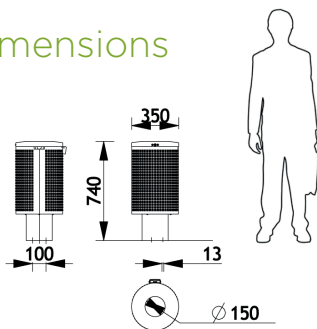

Liner 40 L

Ref. 20 0511 - Weight: 26 kg

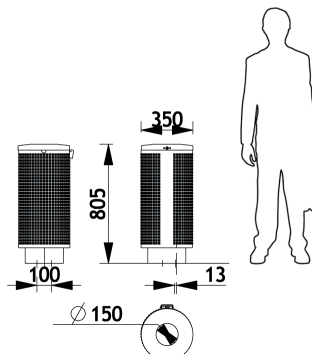

Liner 55 L

Ref. 20 0513 - Weight: 28 kg

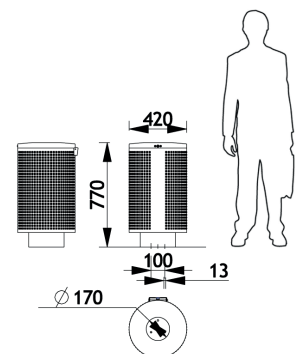

Liner 75 L

Ref. 20 0515 - Weight: 31 kg

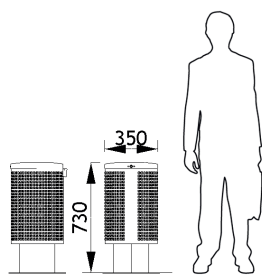

Bag holder 46 L

Ref. 20 0510 - Weight: 23 kg

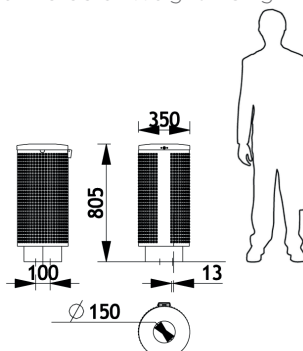

Bag holder 60 L

Ref. 20 0512 - Weight: 26 kg

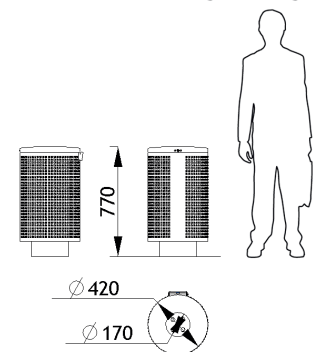

Bag holder 80 L

Ref. 20 0514 - Weight: 29 kg



LITTER BINS | STAINLESS STEEL RANGE - DIAMOND POINT OBLONG



**MODEL SHOWN:
OBLONG 46 L LINER
REF : 20 0527N PLA INX**

Colours

Colours shown:

Body, lid and base : stainless steel

Presentation

The **Oblong litter bin** is ideal for helping ensure your **restricted spaces** stay clean and tidy. It was designed so it can be easily installed in a **footpath**. Thanks to its **small depth** (less than 30 cm), its streamlined contours do not take up much space. An ashtray or snuffer plate can be added, providing the cigarette butts collection. Waste collection is easier, as the bin body swivels, enabling the liner or the bag to be quickly removed.

The different styles, wide selection of colours and textures, options and features mean the Oblong bin ensures ease of use, adaptation to usage conditions and an understated design.

Description

Litter bin with liner: the liner is made of galvanised steel.

Litter bin with bag holder: the bag holder is made of steel.

The body and the frame consists of 2 triangular posts, are made of 2.5 mm thick steel.

The various elements are assembled with stainless steel screws.

The stainless steel is treated, after manufacturing, by sanding, electro-polishing for the lid and bead-blasting for the body, then passivation.

4 sealing points (baseplates version).

Delivered assembled.

Dimensions

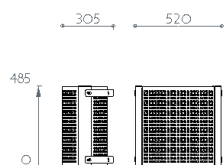

42-liters bin Ref: 20 0520N MUR INX
Weight* with bag holder: 19 kg
38-liters bin Ref: 20 0521N MUR INX
Weight* with liner: 23 kg

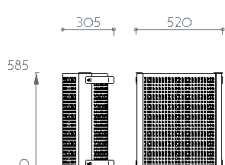

50-liters bin Ref: 20 0524N MUR INX
Weight* with bag holder: 22 kg
46-liters bin Ref: 20 0525N MUR INX
Weight* with liner: 26 kg

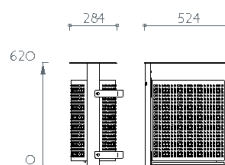

42-liters bin Ref: 20 0522N MUR
Weight* with bag holder: 26 kg
38-liters bin Ref: 20 0523N MUR
Weight* with liner: 30 kg

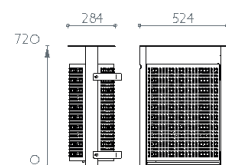

42-liters bin Ref: 20 0526N MUR INX
Weight* with bag holder: 30 kg
46-liters bin Ref: 20 0527N MUR INX
Weight* with liner: 34 kg

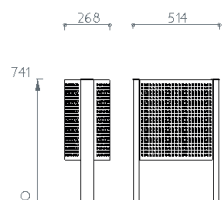

42-liters bin Ref: 20 0520N PLA INX
Weight* with bag holder: 20 kg
38-liters bin Ref: 20 0521N PLA INX
Weight* with liner: 24 kg

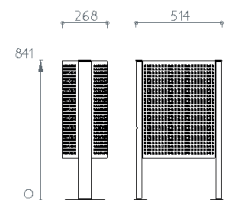

50-liters bin Ref: 20 0524N PLA INX
Weight* with bag holder: 23 kg
46-liters bin Ref: 20 0525N PLA INX
Weight* with liner: 27 kg

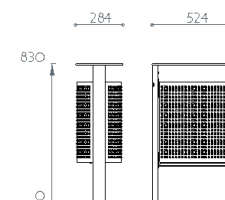

42-liters bin Ref: 20 0522N PLA INX
Weight* with bag holder: 27 kg
38-liters bin Ref: 20 0523N PLA INX
Weight* with liner: 31 kg

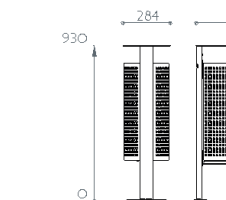

50-liters bin Ref: 20 0526N PLA INX
Weight* with bag holder: 30 kg
46-liters bin Ref: 20 0527N PLA INX
Weight* with liner: 34 kg

*Weight of models with simple lid and on baseplates (without features).



The mark of responsible forestry

Options



Liner

The liner is made of galvanised steel for longevity and high resistance. The litter bin body swivels to make waste collection easier.



Bag holder

The articulated plastic bag holder in steel is attached to the litter bin body. It is fitted with a hoop and a rigid ring. Both components can be removed. The ring folds down onto the hoop to ensure the bag is firmly held in place.



Lock

The stainless steel lock is self-closing. A triangular key, supplied by Sineu Graff, is used to open it.

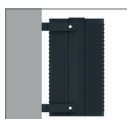

Fixings

On baseplates : The baseplates are made of 6 mm thick steel.

To be buried : extended steels parts, reinforced with Ø4 mm thick steel cornerpiece.

Wall fastenings are in 4 mm thick steel.

Features



Rain shield

The rain shield is made of 5-mm thick steel. In addition to its main function, the rain shield limits the opening, thus prevents its use for household or bulky waste.



Ashtray

It is made of stainless steel. The ashtray is emptied by opening a hatch mounted on 2 spring hinges.

1 liter = 400 cigarettes butts

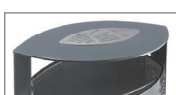

Cigarette snuffer

It is made of stainless steel. It offers users a surface that they can stub out cigarettes on. The surface area has a cigarette-smoke swirl cut by laser, so users can easily recognise it. The cigarette snuffer is made of two 2-mm thick, superimposed, passivated stainless steel plates, to ensure the painted components remain undamaged. The cigarette snuffer is directly fixed to the litter bin body by rounded-head stainless steel rivets.



LITTER BINS | STAINLESS STEEL RANGE - DIAMOND POINT FULL OBLONG

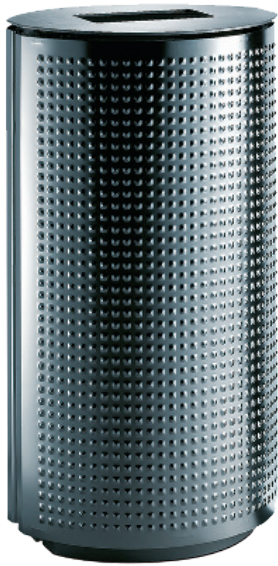

FULL OBLONG
100 L - Ref. **20 0590 INX**

> Colours

Colours shown:

Body, lid and base: stainless steel

> Presentation

The oblong "Diamond Point" litter bin is characterised by a "Diamond Point" pattern for optimum strength and high capacity.

> Description

The all stainless steel litter bin is made of an oblong 2,5 mm thick body with a "Diamond Point" pattern. The frame consists of 2 vertical uprights, 6 mm thick, of a 5 mm thick bottom, of a 5 mm thick lid, of a base, a liner and a lock with a triangular imprint. The stainless steel is treated, after manufacturing, by sanding, electro-polishing for the lid and bead-blasting for the body, then passivation.

The entire litter bin is assembled with screws.

Closing is automatic and opening is to be done with a triangular key.

3 sealing points \varnothing 13 mm.

Delivered assembled.

> Dimensions

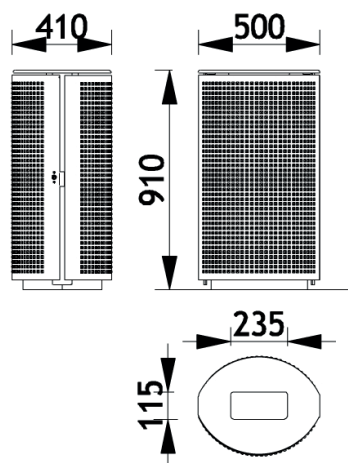

Litter bin with liner

100 L capacity
Ref. 20 0590 INX
Weight: 70 kg





CONTEMPORARY LITTER BIN WITH FLAT LID

Liner: 70 L capacity
Ref. **20 0725 B100 0000 I**

Colours

Colours shown:

Body, lid and base: stainless steel

Presentation

The Contemporary litter bin has been designed to meet today's urban cleanliness challenges. The litter bin is made entirely of stainless steel and has a laser-cut openwork body. This furniture, with its sober and contemporary design, fits easily in any type of environment.

Description

The Contemporary litter bin has a round in shape and has a 70 litres capacity. It is made of 316L stainless steel and consists of a body, a lid and a liner.

The body is made of 3 mm thick laser-cut s metal heet metal.

The 5 mm thick lid is hinged.

The lid is cushioned, when closed, by 2 rubber stops.

Closing is automatic and opening is to be done with a triangular key.

The stainless steel is treated, after manufacturing, by sanding, electro-polishing for the lid and bead-blasting for the body, then passivation.

4 sealing points \varnothing 15 mm.

Delivered assembled.

Dimensions

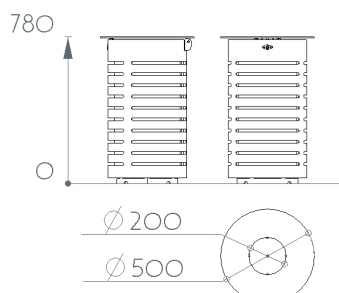

70-liters bin

Ref. 20 0725 B100 0000 I

Weight with liner: 34 kg

