

CONTEMPORARY SORTING SHELTER



PRESENTED PRODUCT:
Selective Shelters 2X240L
Ref 61 0240 TVE-PA
Ref 61 0240 TDR-PA

► Colours

Colors of the presented product:

Anthracite grey	Ral 7016
Yellow green	Ral 6018
Sulfur yellow	Ral 1016

Colors to be chosen from RAL shades, sanded or other textures from AkzoNobel's Futura range.

► Presentation

Sineu Graff offers a variety of solutions to support you in your waste management policy. Sorting shelters are aesthetic furniture, they hide the unattractive waste containers, while they encourage the user to a good behaviour. The shelter encourages selectivesorting thanks to clear signs: a color code identifies the type of waste to be sorted.

► Description

The sorting shelter is mechanically welded and painted zinc-plated steel made of:

- lateral tubular structures (2 frames at the left and right ends),
- steel sheets at the end panels, fixed to the end frames,
- 1 laser cut back panel,
- 1 laser-cut front door, fitted with a semi-automatic stainless steel lock,
- 1 inclined cover with a \varnothing 150 mm front opening, for glass,
- 1 inclined cover with a front opening for packaging and recyclable. The opening is elliptical (220 x Ht 180 mm) and rectangular (415 x Ht 45mm). The rectangular opening is made for pizza boxes),
- reinforcements on the roof, which also avoids seating.

Access for the handling on the side.

It is possible to attach 4 lifting rings (not supplied) to the corners of the upper part of the roof.

Several shelters can be assembled together, using screws through the side frames (caps on the holes).

For optimal protection against rust and long-lasting performance, **the steel elements are first treated by zinc plating, then treated according to our Powder Blast process** (after cleaning and shot-blasting, the parts are coated with a first coat of epoxy powder, and a second coat of polyester powder).

Delivered assembled.

► Dimensions

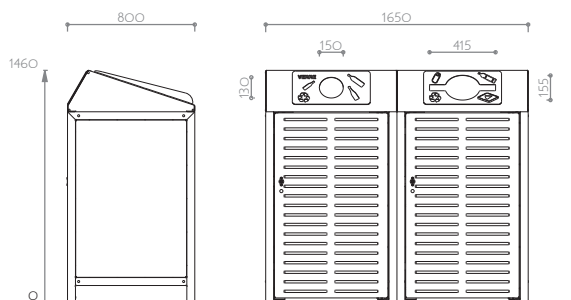

Sorting shelters 2x 240 litres
Weight: 271 kg

