

**PRODUCT CODE:**  
10031V-DARK\_BROWN

**STORK'S NEST SWING - RECYCLED MATERIAL, DARK BROWN**

**SWINGS**



**DEVICE DATA**

**PROJECTION AND VIEW OF THE DEVICE**

**Easily accessible device**

**Compliance with the PN-EN standard:** 1176-1:2024-03

**Number of users :** 2

**Age group :** 2+

**Width :** 3.50 m

**Length :** 2.10 m

**Height :** 2.40 m

**Minimum space required:** 3.50 m x 7.40 m

**Free fall height:** 1.25 m

**Fall area:** 25.90 m<sup>2</sup>

**Foundation depth :** - 0.60 m

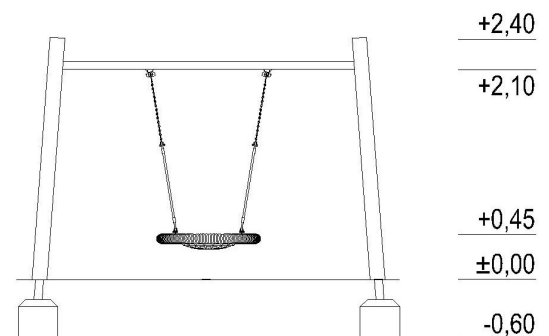
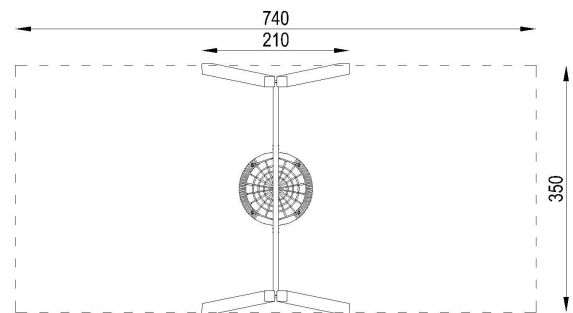

**COMPONENTS**

**Supporting structure:** 1 set

---

**"Nest" seat:** 1 pc.

---

**TECHNOLOGY**

**Structural legs:** beams made of recycled plastic conglomerate , cross-section 100x100mm, brown (dyed in the mass)

---

**Horizontal beam:** galvanized steel, powder-coated gray

---

**Seat:** metal supporting structure, coated with soft black plastic

---

**Chain:** 6mm calibrated chain, stainless steel

---

**End caps:** plastic

---

**Foundations:** concrete class C 12/15 minimum

---

Due to continuous improvement of technical solutions, the presented drawings, including colors and dimensions, may differ slightly from the currently manufactured devices.