

PRODUCT CODE:
10019V-DARK_BROWN

TODDLER DOUBLE SWING - RECYCLED MATERIAL, DARK BROWN BROWN

SWINGS



DEVICE DATA

PROJECTION AND VIEW OF THE DEVICE

Easily accessible device

Compliance with the PN-EN standard: 1176-1:2024-03

Number of users : 2

Age group : 1+

Width : 3.50 m

Length : 2.10 m

Height : 2.40 m

Minimum space required: 3.50 m x 7.40 m

Free fall height: 1.25 m

Fall area: 25.90 m²

Foundation depth : - 0.60 m

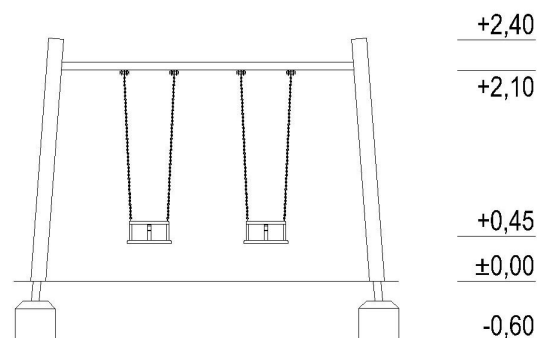
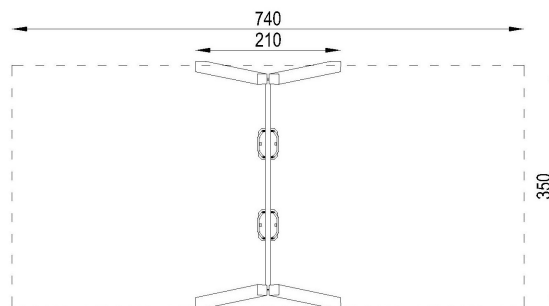

COMPONENTS

Supporting structure: 1 set

Basket seat: 2 pcs.

TECHNOLOGY

Structural legs: composite cross-section beams 100x140mm, made of recycled material consisting of a plastic mix whose main components are polyethylene (LDPE/HDPE), polypropylene (PP) and polystyrene (PS)

Horizontal beam: square steel profile 70x70x3mm, hot-dip galvanized, powder coated

Seats: rubber-coated metal structure

Chain: 6mm calibrated chain, stainless steel

Caps: system plastic caps

Foundations: concrete class at least C12/15

Due to continuous improvement of technical solutions, the presented drawings, including colors and dimensions, may differ slightly from the currently manufactured devices.