

6504



Available colours



RAL 1002



RAL 8025



RAL 5024



RAL 6011



RAL 7047



RAL 7044

Information about the product

Dimensions	100 x 100 cm
Overall height	66 cm
Availability of spare parts	Yes

Technology



A technology that enables **HDPE polyethylene** to be formed into designer furniture from the **Outi collection**. As a result, each piece is both durable and unique.

Warranty



Lifetime

The warranty covers the durability of components made of HDPE (high-density polyethylene), as well as the structural integrity of components made of black steel that has been powder galvanized and powder coated, stainless steel, and components made of hot-dip galvanized steel.



10 years

The Guaranty covers all flaws of the elements made of HPL, HDPE, stainless steel, hot-dip galvanized steel, wooden elements (pine, spruce), revealed during usage, which arise from manufacturing reasons.



5 years

The Guaranty covers all flaws of the elements made of powder coated steel, aluminum, laminate, ropes, elements made in rotomoulding technology, elements made of polyamid, polypropylene elements, revealed during usage, which arise from manufacturing reasons.



2 years

The Guaranty covers all flaws of the elements made of rubber, moving elements (bearings, joints), electronic elements, elements made of EPDM, elements made of plywood and other not mentioned before revealed during usage, which arise from manufacturing reasons.

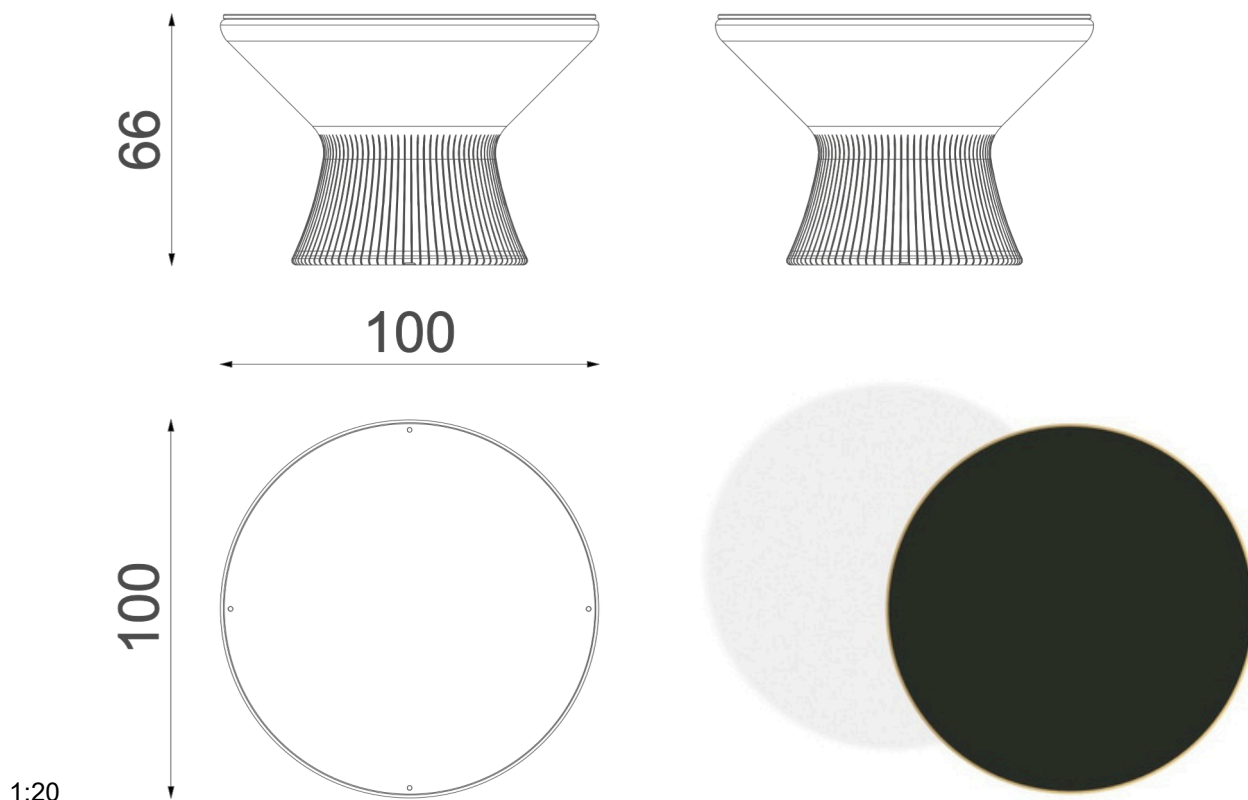

1:20

Product description

6504 Table

Dimensions:

- Product dimensions: 100 x 100cm
- Overall height: 66 cm

The Table is a functional element that naturally complements seating arrangements. The tabletop, made of 13 mm thick HPL, serves as a surface for placing items, dining, or meeting. Its form has been designed as an integral part of the system, ensuring visual and functional coherence with the other modules and supporting the creation of consistent, multifunctional compositions.

It is part of a series of modular furniture designed for public spaces, characterised by high durability and configurational flexibility. The forms are based on smooth lines and rounded geometric transitions, enabling the creation of cohesive arrangements with varied functions and scales. The collection is manufactured using rotomoulding technology with HDPE (high-density polyethylene) granulate, ensuring a uniform material structure, high mechanical resistance, and durability under intensive use. At the same time, it provides resistance to UV radiation, moisture, temperature fluctuations, and mechanical damage, making the elements suitable for both indoor and outdoor environments.

Installation method

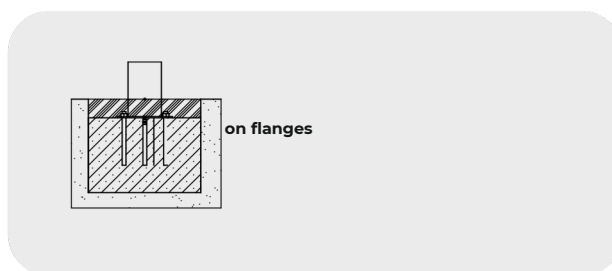

Materials



Rotomoulding technology with HDPE (high-density polyethylene) granulate, ensuring a uniform material structure, high mechanical resistance, and durability under intensive use. At the same time, it provides resistance to UV radiation, moisture, temperature fluctuations, and mechanical damage.



Black HPL panel with a thickness of 8 mm, of the highest quality, completely resistant to moisture and UV radiation.