



Information about the product

Dimensions	187 x 59 cm
Safety zone	523 x 359 cm
Safety zone area	17 m ²
Overall height	200 cm
Free fall height	56 cm
Amount of users	2
Highest element	302 cm
Heaviest element	30 kg
Product complies with EN 1176-1:2017-12	Yes
Availability of spare parts	Yes
Age range	3 -12

According to EN 1176-1:2017-12 norm, the product requires applying a safety surface according to the product's free fall height.

Technology



SHAPE
WAVE MASTER

A method that allows pipes to be bent at any angle while preserving the integrity of the steel surface, enabling sleek and flexible structures.



COLOR
WAVE MASTER

A painting technique that allows combining two colors, which smoothly blend into each other. It enables achieving a natural colour fusion effect.

Functions



Rocking



Balancing



Socializing



Emotion regulation



Grasping

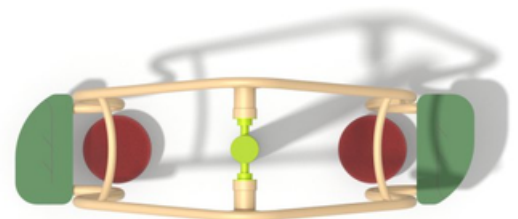

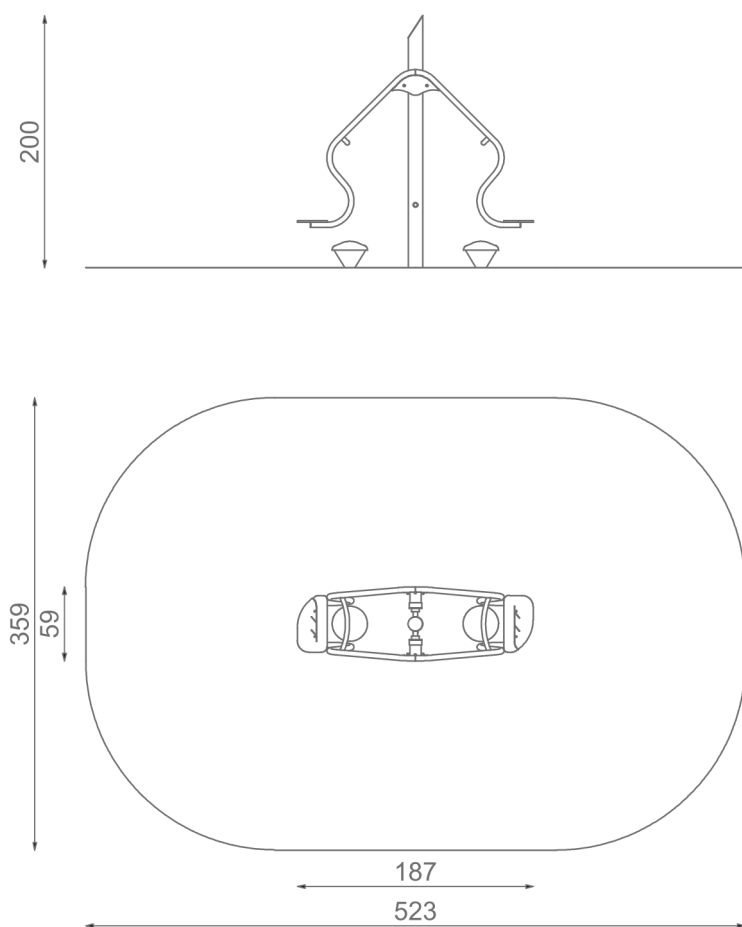

1:60

Due to the height of the free fall of the product, the EN 1176-1:2017-12 norm allows following types of fall- absorbing surfaces:

Material	Description	Minimal layer thickness mm
Concrete		
Bituminous surfacing		
Top layer of the soil		
Turf		
Bark	Chipped bark of coniferous trees (no wood-based materials), the size of the pieces between 20mm to 80mm	300
Wood chips	Mechanically fragmented wood without bark and leaves, size of the pieces between 5 mm to 30	300
Sand or gravel	Particle size between 0,25 mm to 8 mm	300

All types of surfaces need to be prepared by cleaning material and removing extraneous matters. Broken glass is considered the most hazardous. Synthetic material with a particle size of 0,25 mm to 8 mm is not allowed for freefall heights ≥ 56 cm

Installation method

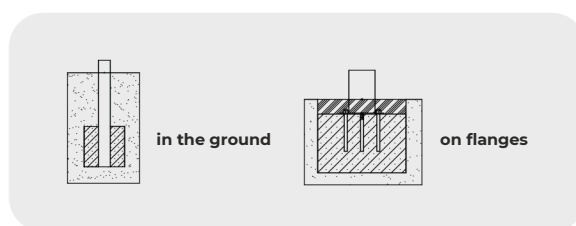

Warranty



Lifetime

The warranty covers the durability of components made of HDPE (high-density polyethylene), as well as the structural integrity of components made of black steel that has been powder galvanized and powder coated, stainless steel, and components made of hot-dip galvanized steel.



10 years

The Guaranty covers all flaws of the elements made of HPL, HDPE, stainless steel, hot-dip galvanized steel, wooden elements (pine, spruce), revealed during usage, which arise from manufacturing reasons.



5 years

The Guaranty covers all flaws of the elements made of powder coated steel, aluminum, laminate, ropes, elements made in rotomoulding technology, elements made of polyamid, polypropylene elements, revealed during usage, which arise from manufacturing reasons.



2 years

The Guaranty covers all flaws of the elements made of rubber, moving elements (bearings, joints), electronic elements, elements made of EPDM, elements made of plywood and other not mentioned before revealed during usage, which arise from manufacturing reasons.

Product description

Dimensions:

- * Device dimensions: 187x45 cm
- * Safety zone: 487x359 cm (17.48 m.²)
- * Total height: 200 cm
- * Free fall height: 56 cm

Materials:

Structure: Main post made of pipe with a diameter of 114 mm. Swing frame made of pipe with a diameter of 42.4 mm and grip bar made of pipe with a diameter of 33.7 mm. All mentioned elements are made of black steel cleaned by shot blasting, protected against corrosion by powder galvanizing and powder coating. The main post is painted using a special painting technique allowing the combination of two colors that smoothly blend into each other. This creates a natural fusion color effect.

Bumpers: made of shock-absorbing EPDM rubber Steps made of 13 mm thick HPL board resistant to moisture and UV radiation. All screws exposed to weather conditions are made of stainless steel

THE DEVICE INCLUDES AT LEAST:

- 1 x frame
- 2 x step
- 2 x bumper
- 1 x horizontal net

Materials



Solid construction elements made of black steel powder galvanized and covered in powder coating paint, resistant to UV radiation.



Elements made of high quality, coloured triple-layer HDPE 15 mm, resistant to moisture and UV.



Elements made of coloured, highest quality HPL 13 mm, completely resistant to moisture and UV.



Rubber bumper made of soft and durable EPDM rubber.