

# 3018

## AQUARIUS



SOCIALIZING



SWINGING



### INFORMATION ABOUT THE PRODUCT

Dimensions	217 x 245 cm
Safety zone	750 x 175 cm
Safety zone area	14 m <sup>2</sup>
Overall height	245 cm
Free fall height	132 cm
Amount of users	1
Product complies with EN 1176-1:2017-12	YES
Availability of spare parts	YES
Age range	1-4



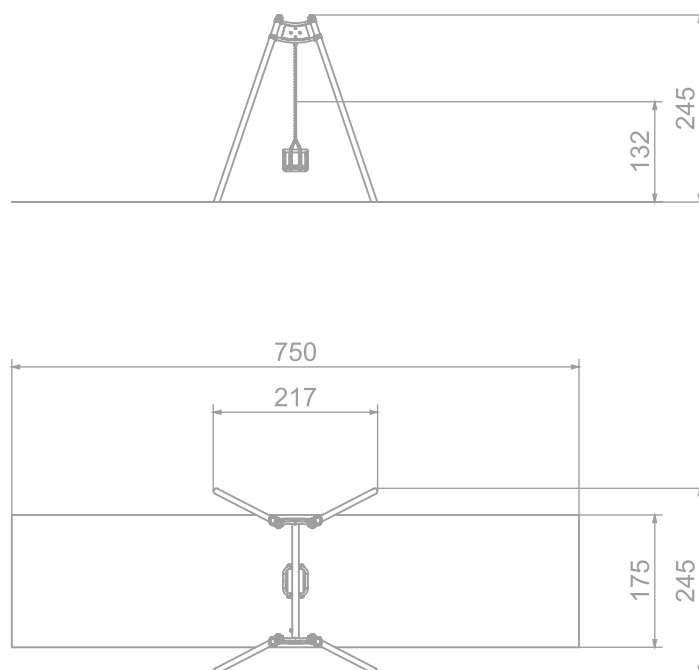

According to EN 1176-1:2017-12 norm, the product requires applying a safety surface according to the product's free fall height.



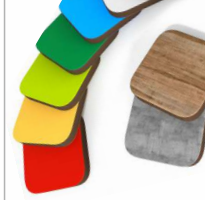

SCALE 1:100

MATERIALS:

<p>SOLID CONSTRUCTION MADE OF STAINLESS STEEL AISI 304 TOTALLY</p>	<p>PLATES OF THE WALLS MADE OF COLOURFUL 13 MM HPL</p>	<p>SAFE PIPE PLUGS MADE OF INJECTION MOLDED POLYAMID</p>
		
<p>SAFETY SEAT MADE OF ALUMINUM AND STAINLESS STEEL COVERED WITH SOFT POLYURETHANE</p>	<p>SWING SLINGS, WITH DOUBLE BEARINGS</p>	
		

OPTIONAL:

<p>THE SEATS ARE MADE WITH AN ALUMINUM CONSTRUCTION COVERED WITH A SOFT EPDM RUBBER</p>	<p>BACK SUPPORT OF THE SEAT WITH STEEL CONSTRUCTION COVERED WITH SOFT POLYURETHANE</p>	<p>SEAT WITH A CONSTRUCTION MADE OF ALUMINIUM AND STAINLESS STEEL, DEDICATED FOR MOTHER AND CHILD</p>
