

3021



SOCIALIZING



SWINGING

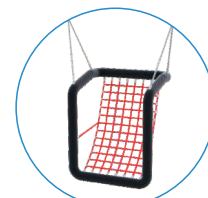

INFORMATION ABOUT THE PRODUCT

Dimensions	217 x 617 cm
Safety zone	750 x 560 cm
Safety zone area	41 m ²
Overall height	245 cm
Free fall height	133 cm
Amount of users	6
Product complies with EN 1176-1:2017-12	YES
Availability of spare parts	YES
Age range	3-12

According to EN 1176-1:2017-12 norm, the product requires applying a safety surface according to the product's free fall height.



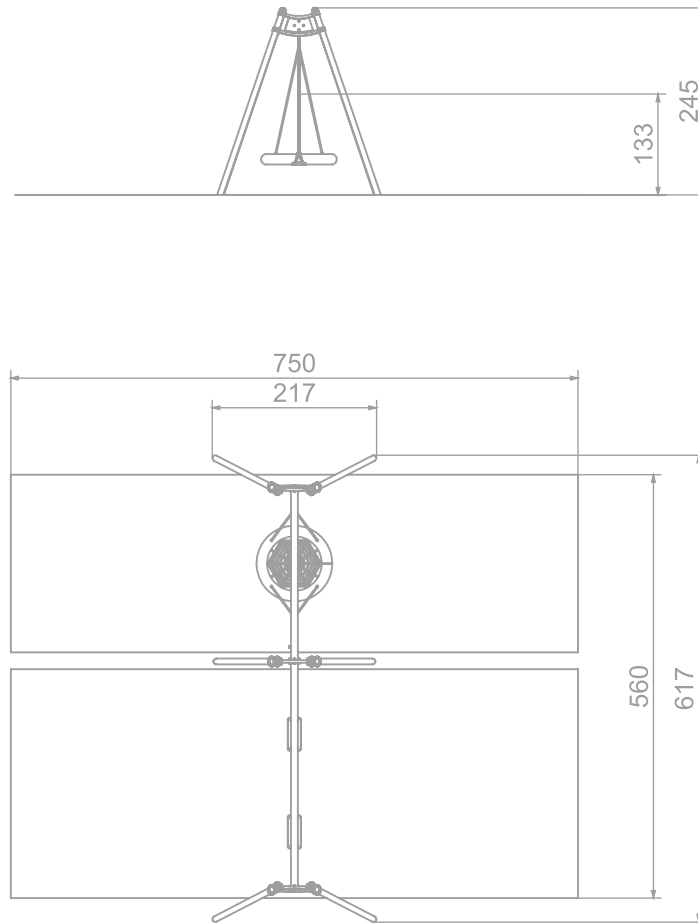

SCALE 1:100

MATERIALS:

<p>SOLID CONSTRUCTION MADE OF STAINLESS STEEL AISI 304 TOTALLY</p>	<p>PLATES OF THE WALLS AND PLATFORMS MADE OF COLOURFUL 13 MM HPL</p>	<p>SAFE PIPE PLUGS MADE OF INJECTION MOLDED POLYAMID</p>
<p>THE SEATS ARE MADE WITH AN ALUMINUM CONSTRUCTION COVERED WITH A SOFT EPDM RUBBER</p>	<p>SWING SLINGS, WITH DOUBLE BEARINGS</p>	<p>„BIRD NEST“ TYPE SEAT WITH A DIAMETER OF 100 CM, HANGED ON 6 MM STAINLESS STEEL CHAINS</p>

OPTIONAL:

<p>SAFETY SEAT MADE OF ALUMINIUM AND STAINLESS STEEL COVERED WITH SOFT POLYURETHANE</p>	<p>BACK SUPPORT OF THE SEAT WITH STEEL CONSTRUCTION COVERED WITH SOFT POLYURETHANE</p>	<p>SEAT WITH A CONSTRUCTION MADE OF ALUMINIUM AND STAINLESS STEEL, DEDICATED FOR MOTHER AND CHILD</p>
<p>APPROVED SEAT – SEAT TYPE – HANGED ON R 6 MM CHAINS MADE OF STAINLESS STEEL METAL FRAME COVERED BY SOFT POLYPROPYLENE ROPE</p>	<p>APPROVED SEAT MADE WITH ROTOMOULDED METHOD, DEDICATED FOR DISABLED USERS</p>	